

“Enhancing the Battery Life Using Super-Capacitor”

¹Mayuri Khaparde, ²Prajakta Wekhande, ³Neeraj Jambhulkar⁴Vivek Jambhulkar, ⁵Rashmi Babhare, ⁶Priyanka Gaurkhede.

¹Students, Suryodaya College of Engineering And Technology, Nagpur

²Students, Suryodaya College of Engineering And Technology, Nagpur

³Students, Suryodaya College of Engineering And Technology, Nagpur

⁴Students, Suryodaya College of Engineering And Technology, Nagpur

⁵Students, Suryodaya College of Engineering And Technology, Nagpur

⁶Assistant Prof, Suryodaya College of Engineering And Technology, Nagpur

Abstract: The objective is to use the excess energy of generator and using it in super capacitor which is further used to enhance the battery life of the vehicle.

Supercapacitor are energy storage device that exhibit such unique feature as high capacitance, high power density, and a long life cycle.

Supercapacitor are used for energy storage undergoing frequent charge and discharge cycle at a high current and short duration.

Supercapacitor are good partners for lithium-ion batteries and other high-density storage technology, supercapacitors are future of electrical vehicle market and will replace batteries in the long term

KeyWords: Supercapacitors, batteries, capacitors, electrodes, voltage, power supplies, electric dynamo motor

I. Introduction

Capacitor are energy storage device that store energy without chemical reaction.

Super-capacitor is a high capacity capacitor with a capacitance value much higher than capacitors, but with lower voltage limits that bridges the gap between rechargeable batteries and electrolytic capacitors.

Super-capacitor stores 10 to 100 times more energy per unit mass than electrolytic capacitors.

Super-capacitor accepts and delivers charge much faster than batteries, and tolerates more charge and discharge cycles.

The range of Super-capacitors is of the order 1F to 2500F.

Filtering with the capacitor is not new. However, supercapacitor with low ESR are a relatively new technology and such a new application will arise.

Supercapacitor with high ESR, suitable for low current applications such as memory backup have existed for year.

The breakthrough in technology is the supercapacitance with low ESR.

1.2 Block diagram

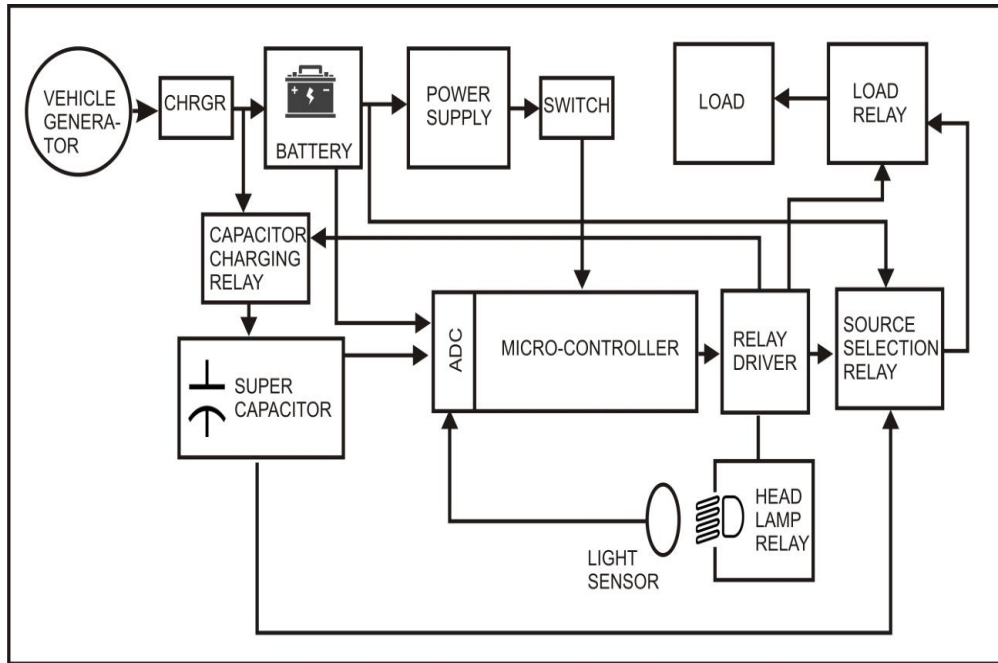

1.2.1Fig: Block diagram of Enhancing the battery life using Super-Capacitor

II. Methodology

The selection of source is controlled by micro controller. The micro-controller is also powered by power supply controlled by switch. The relay driver is used to control all the relays which is controlled by micro controller. Source selection relay is connected to load relay to drive the given load. Relay driver is connected to head lamp relay. The light sensor have LDR(light dependent resistor) which is connected to ADC(analog to digital converter) present inside micro controller. In the proposed block diagram ,the combination of super capacitor and lead acid battery is used to drive the given load. Here, source is the generator of vehicle and is connected to charger. Through the charger the first preference of charging will be given to the battery. When the battery is charged completely, the capacitor will charge through capacitor charging relay. Here there are two sources of voltage ,the supercapacitor and the battery. Both the sources are connected to source selection relay. When the loads are to be used, the first preference of source is super capacitor. When the super capacitor is discharged to a specific limit, the load will be shifted to the battery.

a. System Hardware

Equipment	Ratings
1. Battery	12V/4Amp
2. Supercapacitor	2.7V/100 F
3. Microcontroller	PLC
4. Relay Driver	12V/500mAmp
5. Switch	12V/7Amp
6. LDR	

Advantages

1. Provide peak power and backup power.
2. Extend battery run time and battery life.
3. Reduce battery size, weight and cost.
4. Enable low/high temperature operation.
5. Improved load balancing when used in parallel with a battery.
6. Provide energy storage and source balancing when used with energy harvesters .
7. Minimize space requirements.
8. The big advantages of a supercapacitor is that it can store and release energy instantly -much more quickly than a battery.

Limitation

Low specific energy, holds a fraction of a regular battery linear discharge voltage prevents using the full energy spectrum high self-discharge, higher than most batteries low cell voltage, requires series connections with voltage balancing high cost per watt.

Scope

The scope is very bright. In electronic system, wearable electronics, as also medical implants, supercapacitors are coming up with solutions which could not be thought earlier. Medical implants like peacemaker, knee implants like and others will be powered by them, and they will be harvest energy from body heat and movements. This will obviate in any replacements over life time.

Applications

1. The supercapacitor electric bus is adopted in China.
2. World's fastest charging electric bus: a full charge in 10seconds to its supercapacitor.
3. Supercapacitor electric boat : Ar Vag Tredan means (electric boat) in Breton.
4. Supercapacitor to recover braking energy by car.
5. Filtering with the capacitor is not new. However, supercapacitor with low ESR are a relatively new technology and such a new application will arise.
6. Suoercapcitor with high ESR, suitable for low current applications such as memory backup have existed for year.
7. The break through intechology is the supercapacitance with low ESR.

III. Conclusion

Batteries are generally over at power delivery because of their large source impedance and traditional capacitors cannot hold the energy required to sustained peak load for long periods. Combining a battery with a low ESR supercapacitor give the best of both worlds. The supercapacitors supplies the peak power and the batteries supplies the energy. This paper showed how supercapacitors can because to complements a battery. Transients are suppressed and the runtime of the battery can be extended there by improving system performance. And explanation of the construction of a carbon double layer supercapacitor was given along with a experimental plots of suppression and the runtime extension.

Acknowledgement

The authors wish to thank the faculty of SCET for their assistance and guidance.

References

- [1]. Bopche, L. M., Deosant, A. A., & Ahmad, M. “ Combination of parallel connected super capacitor& battery for enhancing battery life”. 2016 International Conference on Automatic Control and Dynamic Optimization Techniques, vol 12 pp 73-78,Mar 1997.
- [2]. Sarang R. Soni, Chetan D. Upadhyay, HinaChandwani,(2015). Analysis of battery supercapacitor based storage for electrical vehicle. 2015 (IEEE)
- [3]. Mishra, R., &Saxena, R. (2017). Comprehensive review of control schemes for battery and super-capacitor energy storage system. 2017 7th International Conference on Power systems (ICPS).
- [4]. Abedi, M. R., & Lee, K. Y. (2013). Dynamic model analysis and control of a grid connected wind energy system integrated with a super-capacitor bank.2013 IEEE Power& Energy Society General Meeting.doi:10.1109/pesmg.2013.